

Modelling

Computer based modelling has taken an increasingly important place in the primary and secondary raw materials processing industry in the last 5 years. In the metallurgical industry especially, software packages have caused a revolution in a way that was unimaginable only 10 years ago.

The extractive metallurgy group at XPS has developed an expertise in both thermodynamic (FactSage) and mass/heat balance (Metsim) modelling. XPS has been involved with the FactSage program for more than 10 years and consequently has a unique perspective on and thorough knowledge of applying the software to a wide array of applications. Metsim has been used for both hydro- and pyrometallurgical applications; being a strong and well-proven tool in the metal processing industry.

Statistical software is used at XPS for optimizing Design of Experiments (DOE), which includes factorial design and response surface modelling. XPS has separate brochures on **finite element modelling** (COMSOL) and **discrete event modelling** (ARENA or AUTOMOD), which can be used for **mine planning** or **converter aisle scheduling**.

Key Capabilities...

Metsim has been applied in the following situations:

- Mass and heat balance modeling
- Process control (static and dynamic) included
- Flow-sheet optimization
- Recycle-stream optimization
- Flow-sheet development

Successful projects completed by XPS using Metsim are:

- Molybdenum concentrate purification plant in South America
- Complete flow sheet for Kidd Creek Refinery and Smelter
- HPAL laterite flow sheet optimization for Koniambo phase II
- Pyrohydrolysis simulation for alternative laterite flow sheet development
- Hydrometallurgical treatment of copper concentrates

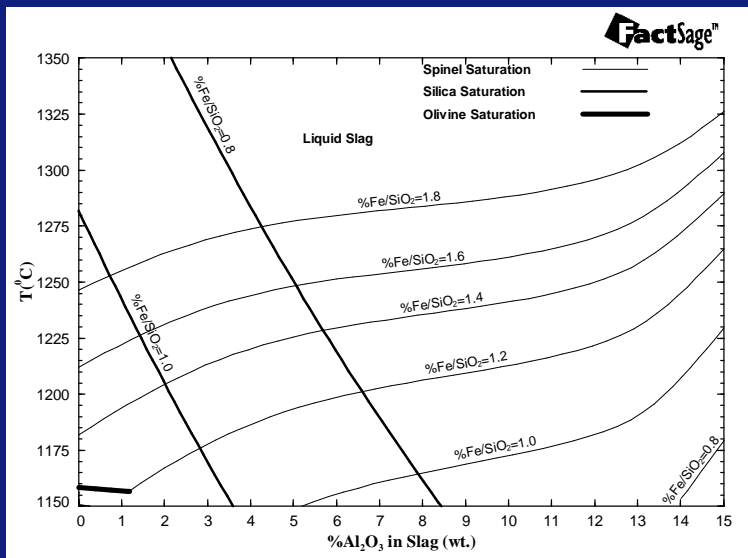
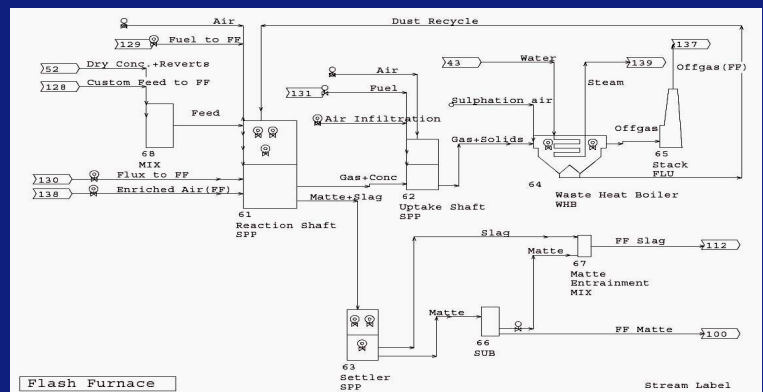

Above: Impact of Al_2O_3 on the Noranda Reactor slag temperature (FactSage)

FactSage is a thermodynamic software package that allows the calculation of equilibrium between matte-slag-metals and gas phases using Gibbs energy minimization.

Successful applications of FactSage at XPS are:

- New feed evaluation for a non-ferrous smelter by making heat and mass balances for smelting and converting
- Minor element partition; e.g. arsenic capacity and emission control (Cu smelter)
- Liquidus calculations; ZnO, MgO, Al_2O_3 and CaO capacity in the Noranda Reactor (Cu Smelter)
- Slag composition optimization of the electric furnace; MgO capacity (Sudbury Smelter)
- Simulation off-gas compositions for different flow sheet scenarios in SO_2 abatement studies (Ni Smelter)
- Simulation of smelting characteristics of FeNi production from limonitic and saprolitic ores (Laterite project)
- Phase speciation during copper anode cooling (Cu refinery)

Contact Us...

[Address] Xstrata Process Support Group, 6 Edison Road, Falconbridge, Ontario, P0M 1S0, Canada
[Phone] +1 (705) 699 3400 [Fax] +1 (705) 699 3431 [E-Mail] extractive@xstrataprocesssupport.ca